

# Digital Transformation of Libraries Supported by AIGC Technology

Jibing Sun

China Coast Guard Academy, Ningbo 315000, Zhejiang, China

**Abstract:** This paper deeply explores the digital transformation strategies of libraries supported by artificial intelligence-generated content (AIGC) technology, aiming to provide theoretical guidance and practical reference for the digital transformation of libraries. The paper first introduces the AIGC technology and outlines its main technical principles and characteristics. Then, for the digital transformation of libraries, the application prospects of AIGC technology are analyzed in three aspects: knowledge management, service innovation, and management decision-making, and corresponding strategic suggestions are put forward. The research finds that AIGC technology can significantly improve the service efficiency and work efficiency of libraries, promote service model innovation and management optimization, and also brings challenges such as hardware adaptability and data validity. The research suggests that when libraries introduce AIGC technology, they need to formulate clear transformation strategies and countermeasures, enhance the corresponding management and technical capabilities of libraries according to the characteristics of AIGC, and ensure the security, effectiveness, and sustainability of technology applications. With the mature application of AIGC, information technology has entered another period of change and will continue to progress. The digital transformation of libraries will also be a continuous dynamic evolution process, which requires continuous exploration and practice to adapt to the rapid changes in technology development and user needs. Therefore, this paper aims to explore how to more effectively use AIGC technology to promote the development of library digitization.

**Keywords:** Artificial Intelligence; Generated Content Technology; Digital Transformation; Library.

## 1. OVERVIEW OF AIGC TECHNOLOGY

AIGC (Artificial Intelligence Generated Content) is usually translated as generative artificial intelligence. It refers to the artificial intelligence that can use a variety of artificial intelligence technologies and methods to learn and identify existing data, and then generate the expected content with appropriate (mainly referring to the generated content needs to conform to the general human cognition) generalization ability, usually called Generative AI. The McKinsey report concludes that generative artificial intelligence aims to interact and collaborate with humans in a way similar to human behavior. AIGC is an integrated application of artificial intelligence technologies and the most promising form of artificial intelligence that meets users' expectations. The expectation for AI to have the ability to create content has germinated since the concept of AI was born. Alan Turing's famous machine intelligence judgment method, the "Turing Test", is actually to test whether a machine can interact with humans to generate content that conforms to human cognition. The technological evolution of AIGC is shown in Figure 1. In the early days, AIGC technology relied on the traditional programming mode of (if-else) based on probability models and rule systems, and its use was extremely limited. Since 2010, with the widespread rise and rapid development of deep learning, a variety of key technologies related to AIGC, such as NLP (Natural Language Processing), DNN (Deep Neural Network), VAE (Variational Autoencoder), GAN (Generative Adversarial Network), and Transformer models, have become increasingly mature. AIGC has achieved remarkable breakthroughs, especially in language generation and visual generation, with its capabilities increasing exponentially and remarkable progress in the multi-modal direction. It has shown great application value in various fields of academia and industry. Many products have been widely promoted in various industries, achieving technical and commercial success and receiving double recognition from the industry and the capital market. DeepSeek and Sora are representatives of them.

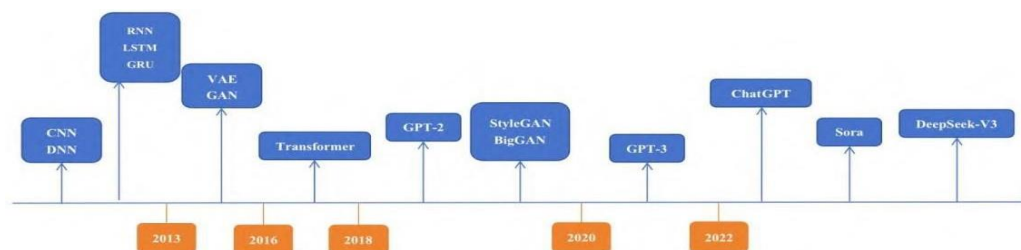

Figure 1: Evolution of AIGC Technology

DeepSeek is a large language model generative artificial intelligence developed by the Chinese technology company DeepSeek. It innovatively adopts the sparse MoE (Mixture of Experts) technology, activating only 5% to 10% of the model parameters during each inference, significantly reducing hardware consumption and power costs. At the same time, it uses a method of dynamically adjusting the model load to maintain the performance level of dense models while reducing resource consumption. Its latest two models are DeepSeek-V3 and DeepSeek-R1. DeepSeek-V3 is suitable for various language processing tasks, achieving efficient inference and low training costs. Based on this, DeepSeek-R1 enhances the capabilities of self-verification, reflection, and long thinking link generation through reinforcement learning, making it suitable for scenarios that require deep reasoning such as academic research, problem-solving applications, and decision support. The low-cost and open-source characteristics of DeepSeek enable it to be quickly applied to various scenarios, significantly reducing the threshold for various industries to deploy large models and promoting the widespread application of AI technology in the industrial sector. The technical architecture diagram of DeepSeek is shown in Figure 2.

Sora is a video generation large model released by OpenAI, an American company. It is a representative product of the development of AIGC towards the multi-modal direction and can automatically generate high-quality video content according to users' text prompts. It uses deep learning technology based on the Transformer architecture and applies a text-conditioned diffusion model. The diffusion model generates high-quality content from random noise through a step-by-step denoising process and finally generates content that conforms to human cognition. It has been proven to have a wide range of application scenarios in the field of high-quality image and video generation. Sora shows good application scenarios in the fields of entertainment, media, education, advertising, content creation, etc., and also has broad prospects in the library industry, which will empower library management and services efficiently and inject new vitality and impetus into the digital transformation of libraries.

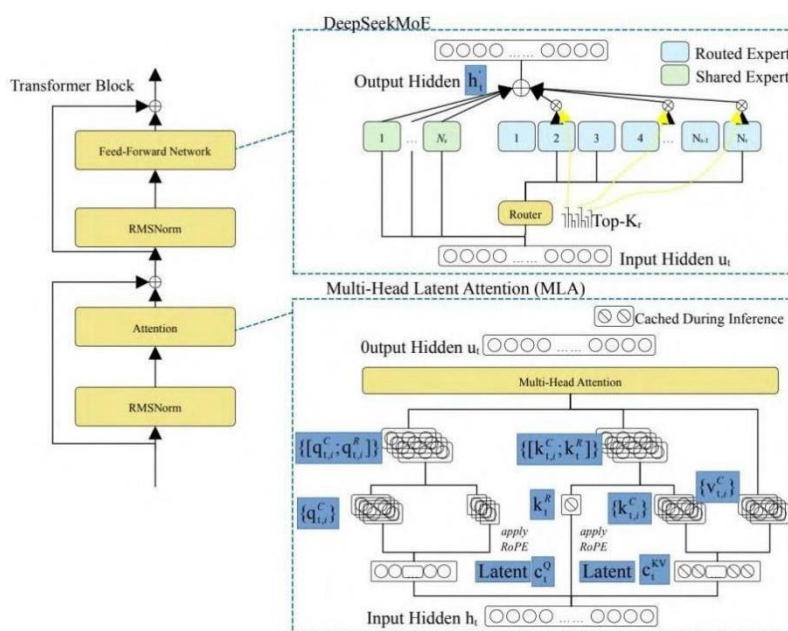

Figure 2: DeepSeek Technical Architecture Diagram

The revolutionary progress of AIGC technology in recent years has greatly improved the content production efficiency, achieved the large-scale production of personalized content, promoted industrial restructuring and business upgrading, opened up a new situation for the social information ecosystem, and brought new opportunities and challenges to all industries. For the library industry, although the concept of digital libraries has been widely promoted, AIGC brings new development opportunities. The future of information technology belongs to artificial intelligence, which not only changes the way of content production but also the means and process of users' access to content. With the help of AIGC, promoting the digital transformation of libraries under the new technological conditions will help libraries find new identity positions and development goals in the new context and better fulfill their responsibilities and missions.

Ukey et al. [1] developed an efficient method for continuous kNN join over dynamic high-dimensional data, providing scalable solutions for real-time similarity queries in evolving datasets. Building on the theme of financial risk management, Yang et al. [2] constructed a multi-dimensional network credit-related transaction risk

map by integrating graph neural networks, enabling early warning capabilities for financial anomalies. Extending this line of financial security research, Shen et al. [3] applied the Whale Optimization Algorithm to financial payment fraud detection, demonstrating the effectiveness of bio-inspired optimization techniques in identifying fraudulent transactions. In a distinct engineering context, Tang et al. [4] contributed to photonic device development through the design and optimization of shallow-angle grating couplers for vertical emission from Indium Phosphide devices. Returning to human-centered AI applications, Sun [5] proposed adaptive interfaces for personalized user experience using a machine learning approach, enhancing user interaction through intelligent adaptation. Wu et al. [6] addressed structural health monitoring by developing a small-sample object detection method for surface cracks in concrete structures of high-rise buildings via multi-level transfer learning, tackling the challenge of limited training data in critical infrastructure inspection. In the area of graph-based computation, Yang et al. [7] introduced HGMatch, a match-by-hyperedge approach for subgraph matching on hypergraphs, advancing the efficiency of complex graph analytical tasks. Pinyoanunpong et al. [8] proposed GaitSADA, a self-aligned domain adaptation framework for mmWave gait recognition, enabling robust biometric identification across varying environmental conditions. Lian and Chen [9] further contributed to foundational AI techniques through research on complex data mining analysis and pattern recognition based on deep learning, enhancing the capacity for knowledge discovery from large-scale data. Addressing challenges in natural language processing, Zheng and Jiang [10] developed a new methodology for Chinese term extraction from scientific publications, improving the precision of domain-specific terminology identification. In the field of visual surveillance, Ding et al. [11] achieved significant progress in unsupervised clothing-changing person re-identification through multi-scale adaptive clustering and local consistency learning. Within the automotive industry, Ziren [12] conducted dynamic optimization and multi-regional performance validation of automotive sales strategies in the United States, offering empirical insights into region-specific market dynamics. Peng et al. [13] exploited aggregation and segregation of representations for domain adaptive human pose estimation, enhancing model generalization across diverse scenarios. Finally, Zheng et al. [14] presented Diffmesh, a motion-aware diffusion framework for human mesh recovery from videos, advancing the state of video-based 3D human reconstruction.

## **2. APPLICATION STRATEGIES OF AIGC TECHNOLOGY IN THE DIGITAL TRANSFORMATION OF LIBRARIES**

### **2.1 Application Strategies of AIGC Technology in Knowledge Management**

In the context of the rapid development of information technologies such as artificial intelligence, the ways and media for humans to acquire knowledge are constantly updated. As an important platform for disseminating knowledge, libraries must face the new situation and undergo changes. This article explores that in the digital transformation, it is particularly important for the core function of libraries to shift from resource management to knowledge management. In terms of knowledge management, integrating AIGC technology with the concept of knowledge graphs and building a knowledge management and sharing platform with knowledge graphs as the core and users as the focus will enable the core competitiveness of libraries to reach a new level in the information age.

Knowledge graphs are semantic networks used to describe entities and their relationships, which can improve the efficiency of knowledge management integration and sharing. They were first proposed by Google and used to improve the performance of its search engine, significantly enhancing the efficiency of information retrieval and management in various scenarios. The traditional way of constructing knowledge graphs mainly relies on manual annotation, which is restricted by both cost and efficiency. With the deep integration of large model technology and NLP technology in the AIGC field, generative artificial intelligence based on LLM (large language model) has brought significant improvements to the construction of knowledge graphs. LLM can efficiently and accurately extract entities, relationships, and attributes from a large amount of unstructured data, enabling the automated construction of knowledge graphs, and making multi-modal knowledge graph construction technology valuable for application.

There are mainly two processes for using AIGC technology to construct library knowledge graphs: knowledge acquisition and knowledge fusion and optimization. In the knowledge acquisition stage, using DeepSeek or similar products as the base model, the unstructured raw information captured from target library resources or other information sources is processed to identify entities, relationships, and attributes, and autonomous classification is achieved with the help of Prompt (prompt words) to form the knowledge graph structure. In the knowledge fusion and optimization stage, various filtering functions, checking functions, and the complementation function of AIGC are used to detect and screen the content of the knowledge graph to remove redundancy and errors.

In the early days, when constructing knowledge graphs, LLM models were affected by context noise and the inherent "knowledge hallucination" of LLM, resulting in the extraction of incorrect relationships, seriously affecting the credibility of the generated knowledge graphs. In 2024, the new SAC-KG model proposed by the MIRA Laboratory of the University of Science and Technology of China solved this problem well. It innovatively constructed two new components, a validator and a pruner, and introduced a knowledge fusion and optimization stage for generating knowledge graphs by LLM. The validator is responsible for performing quantity checks, format checks, and conflict checks on the knowledge graph, while the pruner is responsible for adding the correct knowledge combinations to the knowledge graph after error correction and continuing the new generation process. Compared with traditional methods, the SAC-KG model greatly improves the performance of the model in the error screening stage, making the reliability of the knowledge graph reach a higher level.

Knowledge graphs bring brand-new and more efficient ideas to library knowledge management, laying a good foundation for the digital utilization of knowledge. The introduction of AIGC makes the generation of knowledge graphs no longer rely on manual annotation. On this basis, combined with knowledge graph storage and visualization tools such as the knowledge retrieval system TuGraph based on AIGC semantic recognition, a user-centered and efficient library knowledge management and sharing platform that meets the knowledge economy era is built. The AIGC-based knowledge management model will improve the efficiency of library knowledge management, making knowledge management the core of library work and greatly enhancing the service level of libraries in the knowledge era.

## **2.2 Application Strategies of AIGC Technology in Library Service Innovation**

The powerful performance of AIGC in natural language recognition and generation, as well as text analysis, makes it highly promising in the field of library services, bringing technological opportunities for libraries to provide digital services with higher efficiency and quality.

In terms of reader services, building an AI librarian based on AIGC is currently a hot topic. AI librarian services mainly include various functions such as information retrieval, consultation services, and business processing. The AI librarian will support two input modes: voice and text, provide two input interfaces based on dialogue and the traditional functional UI, and with the help of the feature of AIGC to conduct sentiment analysis on human language expressions, and with the support of technologies such as virtual humans, it will possess extremely strong service capabilities, greatly reducing the service pressure on librarians and significantly improving the efficiency of reader services.

Information retrieval and consultation services will rely on the knowledge management and sharing platform based on the knowledge graph mentioned above. Building a unified question-answering retrieval system for resources, knowledge, library conditions, etc. based on AIGC can greatly improve the convenience of online services. DeepSeek or similar models have powerful semantic understanding capabilities. The new question-answering retrieval system will not only make judgments on relationships such as inclusion or non-inclusion of keywords, but first conduct semantic understanding on the information input by readers and then further process it. Compared with traditional question-answering or retrieval systems, this will greatly reduce the requirements for readers' information retrieval capabilities, and no longer require the input information of users to have relatively clear directivity. In the process of presenting question-answering retrieval results, the implementation of semantic recognition by AIGC also makes it possible to provide more diverse other services. For example, it can provide biographical introductions of authors, analysis of artistic styles, analyze their associations with other authors based on the knowledge graph, provide more resource recommendations for readers, and provide suggestions for other solution channels when readers' needs exceed the scope of current library services.

Business processing can be based on virtual human technology supported by AIGC to provide cross-platform and multi-dimensional online real-person library services. In the digital transformation of libraries, a virtual human IP can be customized for the library to enhance the recognition and brand value of the virtual human, and provide high-efficiency, convenient, emotional and warm services based on high-tech for readers. Collect all the regulations for business processing in the library to form a knowledge base of library conditions and regulations. When readers interact with the virtual human and put forward business processing requirements, AIGC will analyze the input data of readers, query the knowledge base, return the results and processing methods to the virtual human IP at the front end, and the virtual human IP will feedback to readers and jump to the user input interface corresponding to the business handled by the user, and prompt the user to make the next input until the

processing is successful.

AI librarians have been successfully implemented in some libraries. Taking the library of Harbin Engineering University as an example, the library adopted the model of purchasing third-party products to build AI librarians. There are three AI librarians launched, namely Bokan AI Librarian, Chaoxing AI Librarian and VIP AI Assistant, all of which provide access entrances in the form of web pages. Bokan AI Librarian provides functions such as AI book search, AI book recommendation, AI consultation, and AI reading. Chaoxing AI Librarian can obtain knowledge from the library's proprietary knowledge base to solve readers' consultation problems and provide a variety of application tools to fully meet users' needs. VIP AI Assistant focuses on subject services and mainly relies on the vast amount of literature resources contained in the system to solve problems such as readers' literature writing and information query. The AI librarians in this library also have deficiencies after being used by the author. First, the functions are scattered and lack unified scheduling. The above functions are scattered among three AIGC products, resulting in readers having to switch between three pages when using them, lacking unified scheduling in identity authentication, record preservation, and question-and-answer coherence, and having a sense of fragmentation in use. Second, the functions overlap, which is likely to cause confusion among readers. The three AI librarians overlap in functions and lack unified design and planning, making it difficult for users to distinguish the differences when using them. This shows that in the construction of AI librarians, on the basis of external procurement, it is more necessary to do a good job in top-level design within the library, integrate and customize the AI librarian products individually, so as to better serve readers.

In terms of reading promotion, video-based AIGC represented by Sora can be combined with technologies such as the metaverse and virtual reality to provide a virtual reading space at low cost and high efficiency. Sora's high-efficiency video generation ability can achieve a highly interactive virtual reading experience, making the digital collection resources more intuitively presented to readers. In addition, the video generation ability of AIGC can also significantly reduce the economic cost of the library in reading promotion. After mastering simple skills such as the use of prompts, ordinary librarians can obtain videos that meet the promotion needs without systematic learning of video production and editing techniques, without having to spend high costs to find a third party to produce, reducing the financial pressure and time cost, and improving the efficiency of reading promotion.

### **2.3 Application Strategies of AIGC Technology in Library Management Decision Support**

With its powerful data processing and information processing capabilities, AIGC technology can play an important role in the field of library management decision support. By leveraging AIGC technology to comprehensively digitally transform and upgrade the library management mode, it will greatly relieve the pressure on librarians and enhance the scientificity and accuracy of decision-making.

In terms of data analysis and mining in libraries, AIGC will achieve automated data analysis and generate data reports. Although traditional data analysis technologies also deeply apply various tools of modern information technology, they still require managers to have extremely high data analysis literacy, often requiring relevant academic learning experiences and practical operations over a period of time to master proficiently. In reality, librarians engaged in this work often need to recruit corresponding high-quality talents. With the help of AIGC technology, librarians only need to have basic information literacy and extract the massive data generated by readers every year. After entering simple statements, a highly concise analysis report can be generated, which will greatly lower the threshold of reader data analysis. With the data analysis capabilities of AIGC, various libraries can scientifically form their own data analysis reports. Based on the actual situations reflected in these reports, they can identify deficiencies, adjust their management strategies and operation rules, and improve the operation quality of the library.

In terms of library security prevention and control, combined with technologies such as the Internet of Things and cloud computing, and with the laying of hardware sensors, AIGC will achieve real-time monitoring of library equipment and facilities. If there are faults and security hazards, the system can alarm in real time, analyze the health status of library hardware, and generate security reports for library managers to refer to and make decisions on the next deployment. In addition, combined with relevant graphic recognition algorithms, AIGC will be able to analyze the passenger flow and generate relevant analysis conclusions. Library managers can make accurate judgments on the passenger flow situation in the library based on the analysis conclusions of AIGC, so as to reasonably arrange the deployment of personnel, software, and hardware in the library according to the changes in passenger flow and ensure the safe and controllable opening of the library.

In terms of improving the professional qualities of library staff, with the help of AIGC technology, a knowledge base for library staff can be formed, creating a knowledge graph of various types of information about the library and establishing a user-friendly front-end access interface. This will enable cross-departmental knowledge sharing among library staff, enhancing their overall understanding of the library and the efficiency of cross-departmental collaboration. Currently, library operations are becoming increasingly diversified, and the division of labor among different departments is becoming relatively more distinct. As a result, many library staff often lack an overall understanding of the library. Moreover, in the daily operations of the library, there are often some extremely detailed common-sense issues that require library staff in each department to have a certain understanding to avoid unnecessary omissions. The convenient-to-access and queryable knowledge sharing system for library staff formed with AIGC technology will greatly improve the professional qualities of library staff and the management efficiency of the library.

In terms of library operation and office work, AIGC functions can be easily incorporated into the daily work processes of library staff, significantly enhancing their work efficiency in various aspects such as official document writing, text proofreading, and legal consultation. In combination with technologies such as the Internet of Things, AIGC technology can digitalize asset management and improve the quality of library asset management. With the text analysis and generation functions of AIGC, the work pressure of library staff in text-related matters can be greatly reduced. For example, in the daily shift scheduling of library staff, with the help of AIGC technology, staff can easily generate a scientific and reasonable shift plan that meets the needs of the library.

In terms of practical strategies, building a library management platform based on AIGC is one of the feasible paths to further improve management efficiency and maximize the potential of relevant software and hardware. This management platform can provide multiple functions such as data analysis and mining, security prevention and control, improvement of staff qualities, and knowledge sharing discussed above, and offer various AI tools such as text proofreading and legal consultation for library staff to use in their daily work. The system can adopt a strategy of first building in modules and then integrating them unifiedly. First, ensure the integrity of each module, and then ensure the unity of the entire system. Provide access entrances for multiple media such as the computer terminal and mobile platforms, coordinate the AIGC and other software usage requirements in library management within the library, and deeply integrate library management with this system to make it an important tool for library management decision-making.

### 3. RISK CHALLENGES AND RESPONSE STRATEGIES

The application of AIGC technology in the digital transformation of libraries also poses certain risks and challenges, mainly reflected in the following two points. First, the effective application of AIGC technology relies on powerful hardware support and corresponding computing power to make the output of AIGC meet the expectations. With the wide promotion of the domestic open-source large language model DeepSeek, the practice of AIGC technology, especially the local deployment of large models, has reached a certain scale. From the currently implemented cases, a considerable number of them have poor experiences and do not achieve the expected results. The reason is that the scale of the model is still small, mainly restricted by the library's hardware, that is, the current computing power is not sufficient to support the stable operation of the corresponding scale of the model. As a result, a smaller-scale model is selected as a compromise, leading to limited AIGC application capabilities upon implementation and a significant reduction in practical value, which is not sufficient to support the huge computing requirements of the library's digital transformation. Although DeepSeek has lower computing power requirements compared to foreign models such as ChatGPT, computing power is the biggest limiting factor affecting AIGC output. With the advancement of the library's digital transformation, the computing power requirements will surely continue to rise, and the hardware cost will become increasingly large, which will affect the further promotion of AIGC applications. In this case, AIGC technology can be combined with cloud computing technology to build an inter-library computing power sharing alliance and deploy the AIGC technology backend in the cloud. This will avoid computing power waste, improve the utilization rate of hardware, reduce the library's computing power cost, and prevent the application of AIGC technology in libraries from becoming a low-value project that requires a large amount of financial resources and consumes a large amount of hardware.

Second, AIGC technology requires a large amount of data support; otherwise, it will become "water without a source." Data is another major factor driving the effectiveness of AIGC technology besides computing power, and the importance of data will rise to an unprecedented level in the AIGC era. If libraries do not build their own characteristic knowledge databases, it will lead to a lack of a starting point for the advancement of AIGC, and even the AIGC applications produced will be highly homogeneous, with reduced practical value and disproportionate

output. On the other hand, if truly valuable data cannot be input into the application process of AIGC, without reasonable screening and discrimination, resulting in a large amount of invalid, incorrect, and redundant data in the input of AIGC, it will lead to the AIGC in libraries having no practical value for readers, lacking competitiveness. In the long run, when AIGC applications become the main way for readers to obtain information in the future, if the relevant work in libraries is not improved, it is very likely that due to the low application value of AIGC, the library will lose its service advantage and thus cause a loss of readers. This requires libraries to formulate corresponding data strategies and development roadmaps, and re-examine the important value of data during the process of digital transformation. It is generally implemented in three stages. The first stage is the strategic planning period. First, based on the current situation and identity positioning of the library, do a top-level design, sort out the core business scenarios and requirements of the library, determine the data construction goals, establish a data management framework, and formulate data management standards and security strategies. Then, select the technical direction according to the top-level design, mainly including the data storage mode, analysis tools, and related technology stacks, etc. Finally, carry out the construction of the library data team, clarify the division of responsibilities, and lay a human resource foundation for the implementation work in the second stage. The second stage is the data infrastructure construction period, which requires building a data collection software system, connecting with various software, hardware systems and resource libraries used in the library, realizing the orderly introduction of data, and finally completing the construction of the data warehouse or data lake. In this stage, the construction of data processing tools also needs to be completed. First, preliminarily process the data to ensure data quality and provide tool guarantees for data governance in the third stage. The third stage is the data governance and quality improvement period. In this stage, it is necessary to repeatedly detect the integrity, uniqueness, and timeliness of data, reduce the generation and accumulation of invalid and redundant data. And check whether the settings of various permissions and the hierarchical access of roles are reasonable and effective. The fourth stage is the data optimization and integration period. In this stage, the focus is on optimizing the application value of data and fields, detecting whether the rule definitions of data meet the requirements of various application scenarios under the AIGC background, and verifying whether the field settings meet the application requirements of the library in real scenarios, and improving the maturity of data. After the above four stages are completed, the data construction has been basically completed. However, library managers should also have a long-term concept. In the subsequent data use and management stages, they should continuously maintain the concept of "data construction", regularly re-sort out the business processes and data collection and analysis processes, optimize the data management rules, and ensure the vitality of the library data management construction. In the long run, transform "resource construction" into "data construction", transform resources into data that can be directly used by readers in the AIGC era, and pay attention to the quality and specialization of "data construction", so that under the background of the large-scale application of AIGC, the library can find its new identity positioning in the new knowledge sharing context.

#### 4. CONCLUSION

The application prospect of AIGC technology in the library industry is very broad. It empowers the digital transformation process of libraries, and will largely reshape the service and management models of libraries. Library managers and staff should have a profound understanding of this technology, understand its advantages and risks, actively promote the implementation of new technologies at all levels of library services and management, and make targeted adjustments to library operation strategies according to the characteristics of new technologies. While enhancing computing power through hardware construction, attention should be paid to data construction to lay a solid foundation for the application of AIGC technology. Currently, AIGC technology will continue to make rapid progress in the future. On the one hand, the scale of the model continues to increase, the computing power increases significantly every year, and the understanding and generation capabilities in multi-modal fields such as images, audio, and video are gradually stable and reliable. The application scope of AIGC technology will become more extensive. On the other hand, small-scale AI technologies represented by distillation have been continuously mature, and the costs are also continuously decreasing. Future AI deployments will be very common, and every terminal in the library may run an independent AI model like the new Apple mobile phone, which will reduce the deployment cost of AI and improve the AI response efficiency. Moreover, with the continuous attention of researchers in various disciplines to AIGC technology, the cross-disciplinary application of AIGC will continue to mature, and various applications of AIGC deeply integrated with other fields will become gradually mature and the usability will continue to improve. In the future, AIGC technology will become a library foundation like electricity, network, and RFID.

Facilities are deeply bound to libraries. Driven by AIGC technology, technologies such as the Internet of Things, cloud computing, and virtual reality will regain new vitality. The digital transformation of libraries will continue to

deepen and advance, moving towards unmanned, imperceptible, and unrestricted directions. Library practitioners should pay attention to the development and evolution of technology, do a good job in knowledge accumulation and technology introduction, continuously iterate the technical orientation of library construction and management, and keep up with the times to improve the reader experience of libraries, so that libraries can keep up with the times under the background of new technologies and be recognized by the industry and society.

## REFERENCES

- [1] Ukey, N., Zhang, G., Yang, Z., Li, B., Li, W., & Zhang, W. (2023). Efficient continuous kNN join over dynamic high-dimensional data. *World Wide Web*, 26(6), 3759-3794.
- [2] Yang, X., Zheng, X., & Lu, Q. (2025, October). Construction and early warning of multi-dimensional network credit-related transaction risk maps by integrating graph neural network (GNN). In *Proceedings of the 2025 2nd International Conference on Digital Economy and Computer Science* (pp. 919-923).
- [3] Shen, Zepeng, et al. "Research on Application of Whale Optimization Algorithm in Financial Payment Fraud Detection." *2025 4th International Conference on Artificial Intelligence, Internet and Digital Economy (ICAID)*. IEEE, 2025.
- [4] Tang, Yingheng, et al. "Design and Optimization of Shallow-Angle Grating Coupler for Vertical Emission from Indium Phosphide Devices." (2020).
- [5] Sun, L. (2025, November). Adaptive Interfaces for Personalized User Experience: A Machine Learning Approach. In *Proceedings of the 2025 International Conference on Artificial Intelligence and Sustainable Development* (pp. 457-462).
- [6] Wu, J., Luo, L., & Liao, N. (2025). Small-Sample Object Detection of Surface Cracks in Concrete Structures of High-Rise Buildings via Multi-Level Transfer Learning. *Innovation & Technology Advances*, 3(2), 57–72. <https://doi.org/10.61187/ita.v3i2.262>
- [7] Yang, Z., Zhang, W., Lin, X., Zhang, Y., & Li, S. (2023, April). HGMatch: A Match-by-Hyperedge Approach for Subgraph Matching on Hypergraphs. In *2023 IEEE 39th International Conference on Data Engineering (ICDE)* (pp. 2063-2076). IEEE.
- [8] Pinyoanuntapong, Ekkasit, et al. "Gaitsada: Self-aligned domain adaptation for mmwave gait recognition." *2023 IEEE 20th International Conference on Mobile Ad Hoc and Smart Systems (MASS)*. IEEE, 2023.
- [9] Lian, J., & Chen, T. (2024). Research on Complex Data Mining Analysis and Pattern Recognition Based on Deep Learning. *Journal of Computing and Electronic Information Management*, 12(3), 37-41.
- [10] Zheng, H., & Jiang, T. (2025). A New Methodology for Chinese Term Extraction from Scientific Publications. *Innovation & Technology Advances*, 3(2), 19–45. <https://doi.org/10.61187/ita.v3i2.222>
- [11] Wu, J., Luo, L., & Liao, N. (2025). Small-Sample Object Detection of Surface Cracks in Concrete Structures of High-Rise Buildings via Multi-Level Transfer Learning. *Innovation & Technology Advances*, 3(2), 57–72. <https://doi.org/10.61187/ita.v3i2.262>
- [12] Y. Ding, Z. Ye, I. Xu, S. Lyu and L. Zhang, "Multi-Scale Adaptive Clustering and Local Consistency Learning for Unsupervised Clothing-Changing Person Re-Identification," in *IEEE Transactions on Information Forensics and Security*, vol. 21, pp. 2889-2904, 2026, doi: 10.1109/TIFS.2026.3671089.
- [13] Ziren, Z. (2026). Dynamic Optimization and Multi-Regional Performance Validation of Automotive Sales Strategies in the United States. *Academic Journal of Natural Science*, 3(1), 1-7.
- [14] Peng, Qucheng, Ce Zheng, Zhengming Ding, Pu Wang, and Chen Chen. "Exploiting Aggregation and Segregation of Representations for Domain Adaptive Human Pose Estimation." In *2025 IEEE 19th International Conference on Automatic Face and Gesture Recognition (FG)*, pp. 1-10. IEEE, 2025.
- [15] Zheng, Ce, et al. "Diffmesh: A motion-aware diffusion framework for human mesh recovery from videos." *2025 IEEE/CVF Winter Conference on Applications of Computer Vision (WACV)*. IEEE, 2025.